

Einbauanleitung | Manuel d'instruction de montage | Manuale di istruzioni per l'installazione
Manual de instrucciones de instalación montaje

Fitting
Instruction
Fitting
Instruction
Manual

Contents

CONTENTS

ENGLISH	2
Vehicle Details.....	2
Installation Precautions	4
Parts View	5
Pre Installation	6
Drive Belt.....	7

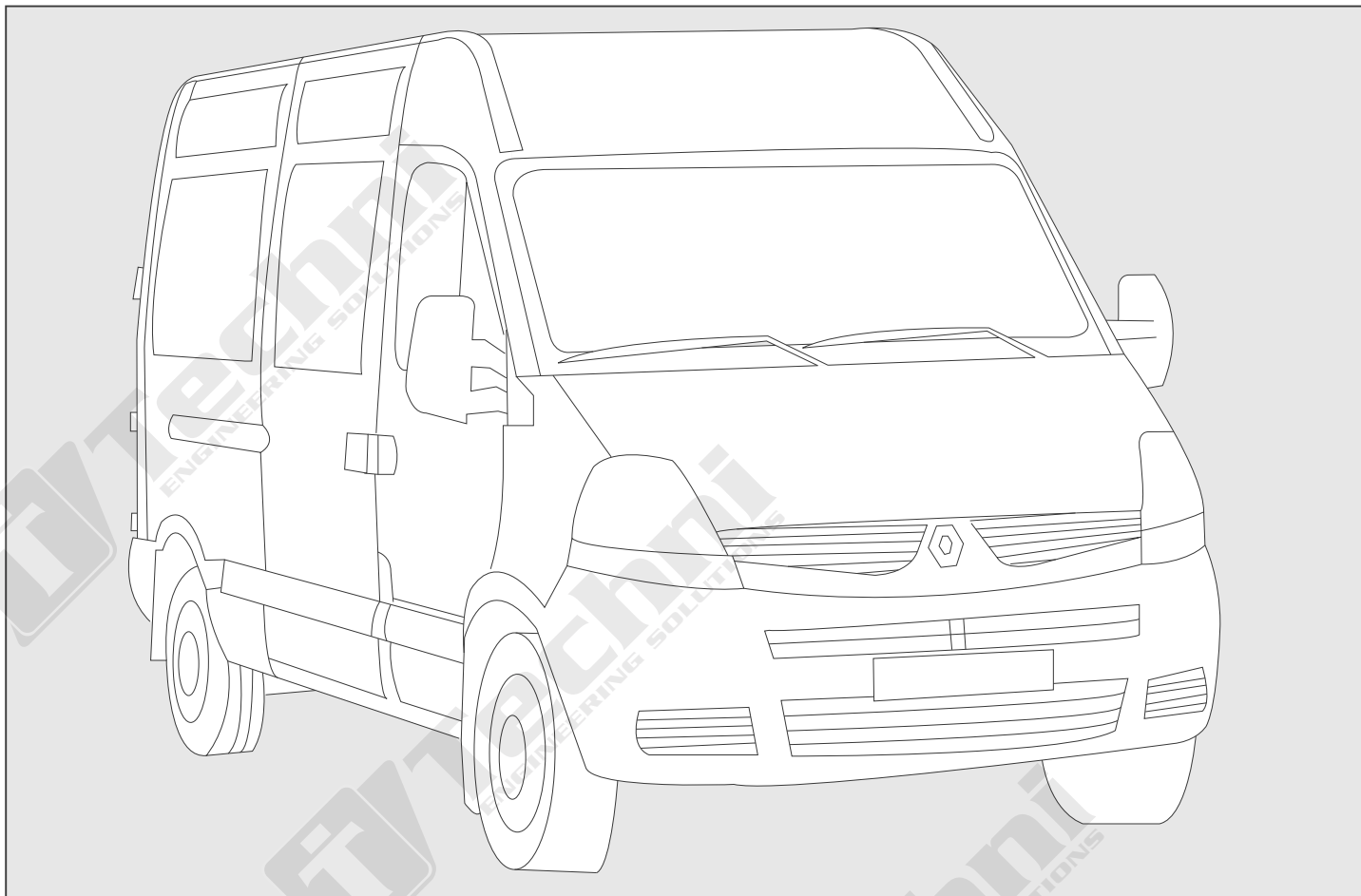

VEHICLE DETAILS

Manufacturer	Renault, Vauxhall / Opel/ Nissan
Make	Trafic, Vivaro, Primastar
Model	2.0 d Ci / CDTi
Engine CC	1995cc
Engine Details	90 / 115 PS
Year	2006>
Chassis Nos.	N/A
LHD	YES
RHD	YES
PAS	YES
A/C	NO
Voltage	12v

KIT DETAILS

Kit Part No.	0500.3512
Description	Standard Kit
Compressor RPM	4441 @ Max Engine
	Power Output
Fitting Time	45 Minutes
Suction Fitting	90°
Discharge Fitting	90°
Belt Type	7PK
Belt Part No.	0820.2141

RECOMMENDED COMPRESSORS

SELTEC	TM-13 HS	TM15-HS	TM16-HS
Comp No	0381.0152	0381.0012	-
Seltec No.	48844320	48845141	-
Mounting	Ear	Ear	-
Rotor	8PV	8PV	-
Armature	SL	SL	-
Diameter	123	123	-
Voltage	12	12	-
Orientation	V	V	-
Fitting	3/4 x 7/8	3/4 x 7/8	-
Manifold	Bolt	Mono	-

SANDEN	SD5H09	SD5H14	SD5H15
Comp No	-	0300.0461	0300.2001
Sanden No.	-	6629	8026
Mounting	-	Ear	Ear
Rotor	-	7PV	6PV
Armature	-	SL	SL
Diameter	-	124	125
Voltage	-	12	12
Orientation	-	V	V
Fitting	-	3/4 x 7/8	3/4 x 7/8

Notes

--

COMPRESSOR KIT CONFIGURATIONS

PART NUMBER	COMPRESSOR KIT PART NOS				DESCRIPTION	QTY.
	0513.3512	0515.3512				
0381.0152	●				TM13 Ear Mount 8PV 3E 123 12V V 3/4 x 7/8 Bolt	1
0381.0012		●			TM15 Ear Mount 8PV SL 123 12V V 3/4 x 7/8 Bolt	1

● = Additional parts to standard kits.

FOREWORD

- The purpose of this manual is to facilitate the installation of a direct drive compressor. The information given is merely instructive, should any complications arise contact the Technical department. The manufacturer's warranty does not cover any problems caused by defective installation or alterations made unless authorised. The manufacturer shall not be responsible for any injury, damage or loss caused directly or indirectly as a result of using this manual or the information contained within it.

1 SAFETY MEASURES:

Before fitting the Compressor adapter drive kit, ensure the following for damage:

- Inner and outer trim and body work
- Engine idle pace
- Check all the vehicle functions

Check list:

- Ensure that the right kit has been selected
- Before installing, check that all the correct pieces are present; also ensure that there are no missing or broken pieces
- When fitting, make sure the vehicle is properly protected against damage.

Installation apparatus

- Calibrated torque wrench
- Hand service tools
- Protective covers and shields

2 PRECAUTIONS

- Detach the battery negative lead.
- Torque all bolts where stated using a calibrated torque wrench.
- Take extreme care with moving parts.
- Remove the vehicle's ignition key and keep it with you.
- Wear eye safeguards and to make sure that liquid refrigerant never touches your skin





Caution: Measures must be followed accurately to steer clear of the possibility of damage to individuals

Warning: This calls awareness to actions which must be pursued to avoid damage to the components.

NB: This calls awareness to make the job easier or gives useful information.

STANDARD FASTENER TORQUE VALUES

- In the absence of specific torque values detailed in this fitting instruction manual, the following chart can be used as a guide to the maximum safe torque for specific size and grade of fastener.

STRENGTH								
	Max Torque		Max Torque		Max Torque		Max Torque	
Dia / Pitch	lb.ft	Nm	lb.ft	Nm	lb.ft	Nm	lb.ft	Nm
M5 x 0.80	2	3	4.5	6	6.5	9	7.5	10
M6 x 1.00	4	5.5	7.5	10	11	15	13	18
M8 x 1.25	10	13	18	25	26	35	33	45
M10 x 1.25	20	27	39	53	57	78	66	90
M10 x 1.50	18	25	37	50	55	73	63	86
M12 x 1.75	33	45	63	85	97	130	111	150
M14 x 2.00	55	75	103	140	151	205	177	240
M16 x 2.00	85	115	159	215	232	315	273	370

PARTS VIEW

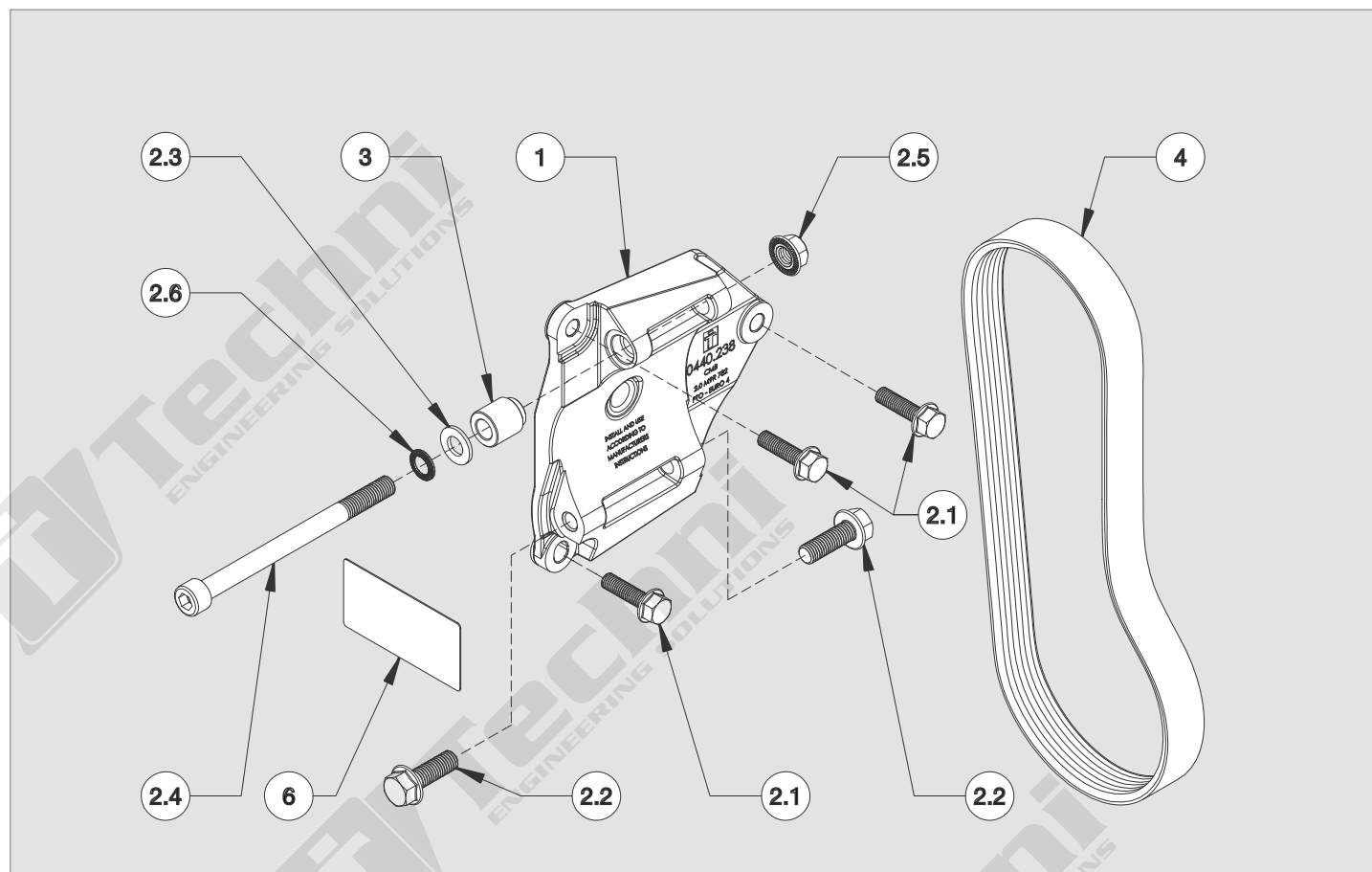

ITEM	PART NO.	DESCRIPTION	QTY.	COMMENTS
1	0440.2383	Compressor Mount Bracket	1	-
2	0290.3512	Fastner Pack	1	Not shown
2.1	2704.0091	Hex flange bolt Durlok - M8 x 30 : 1.25 - 12.9	3	-
2.2	2705.0491	Hex flange bolt Durlok - M10 x 30 : 1.50 - 12.9	2	-
2.3	2809.0011	Washer M10 flat DIN 125 - A 10.5	1	-
2.4	2705.0301	Hex socket head cap screw M10 x 130 : 1.50 - 12.9	1	-
2.5	2735.0071	Durlock hex flange nut - M10 : 1.50	1	-
2.6	2809.0101	M10 schnorr safety washer type 'S'	1	-
3	2803.3403	Compressor spacer	1	-
4	0820.2141	Belt - Poly groove 7 PK	1	-
5	2901.3512	Installation instructions - 0500.3512	1	Not shown
6	2902.3512	Belt Label - 0500.3512	1	-

PRE-INSTALLATION

N.B Prior to commencing work, please examine the instructions with care. The alphabetical symbols on the diagram relate to written instructions, numerical symbols relate to the parts listing.

Remove the following parts:

1. Remove the original drive belt **(A)** and discard - Fig 1.

NB: Please refrain from using "Loctite" unless otherwise notified.

2. Remove the M8 bolts **(B)** securing foolish pulley assembly **(C)**- Fig 2.
3. Discard bolts **(B)** and pulley assembly **(C)** - Fig 2.

4. Fit the supplied compressor mount bracket **(1)** using supplied bolts **(2.1)** - Fig 3.
5. Torque M8 X 30 bolts **(2.1)** to 25 Nm / 18.5 Lb ft - Fig 3.

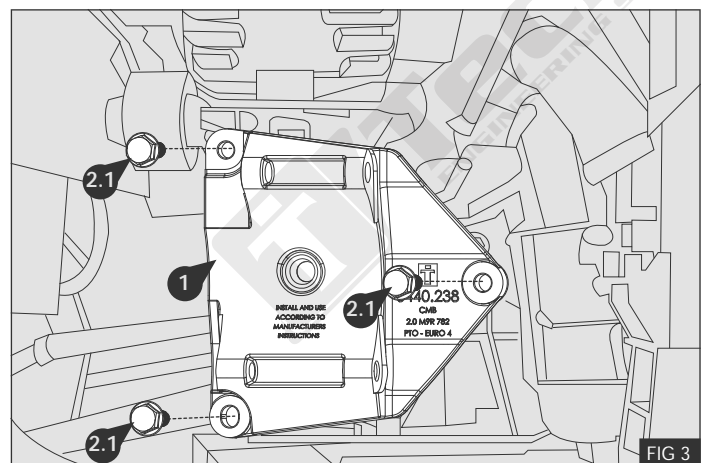
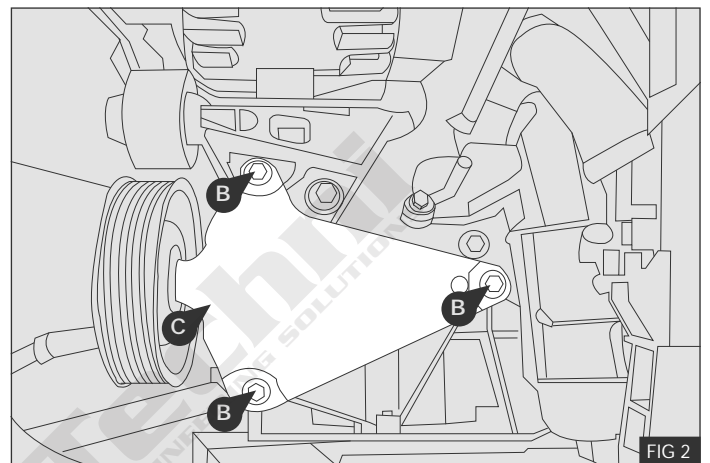
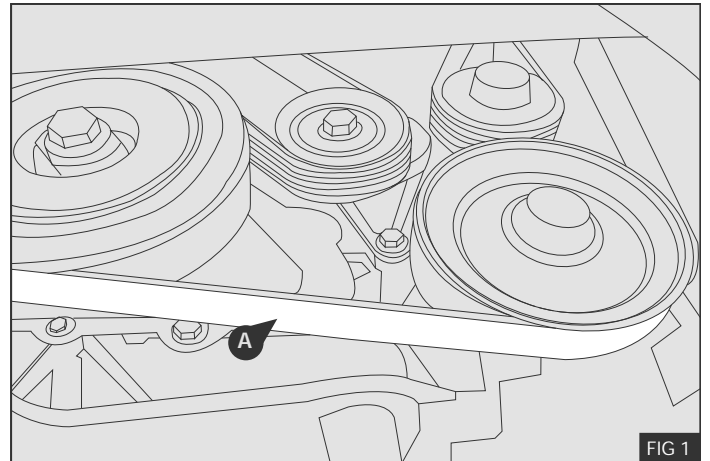

- Fit the supplied CMB insert **3** - Fig 4

NB: Please refrain from using "Loctite" unless otherwise notified.

- Secure the top of the compressor to the mount bracket **1** using bolt **2.4** with spring washer **2.6** flat washer **2.3** and nut **2.5**. Secure the bottom of the compressor using bolts **2.2** - Fig 5.
- Torque M10x130 bolt **2.4** to 50Nm / 37Lb ft - Fig 5.
- Torque M10x 30 bolts **2.4** to 63Nm / 46Lb ft - Fig 5.

#

DRIVE BELT

- Fit the supplied drive belt **4** to the vehicle - Fig 6.

- Crankshaft Pulley
- Tensioner
- Vacuum Pump
- PAS Pump
- Back Idle Pulley
- Alternator
- Compressor

Note: Make sure that the drive belt is fitted into the correct groove of the compressor clutch as shown - Fig.7

Seltec PV8 has the same gauge line as the Sanden PV6 & PV7, belt is fitted to front groove.

Sanden PV8 has a unique gauge line, belt is fitted to second groove.

FINISH

- Run the engine with the Compressor Clutch engaged for five minutes, check all components and fit belt label stickers

